

AT THE CONTRACTORS OPTION THIS AREA MAY BE CONSTRUCTED OF BASE MATERIAL AT NO ADDITIONAL COMPENSATION

STA. 174+25.33 TO STA. 175+80.00

SHOULDER PAVEMENT DETAIL
N.T.S.

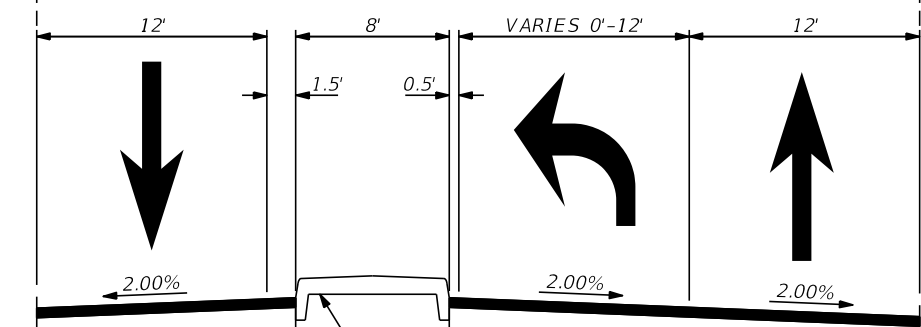

TYPE IV TRAFFIC SEPARATOR
OPTION 1, PER FDOT INDEX 520-020

STA. 113+69.79 TO STA. 117+00.00
 STA. 130+93.92 TO STA. 134+23.92
 STA. 140+48.13 TO STA. 143+78.13
 STA. 166+65.61 TO STA. 169+95.61

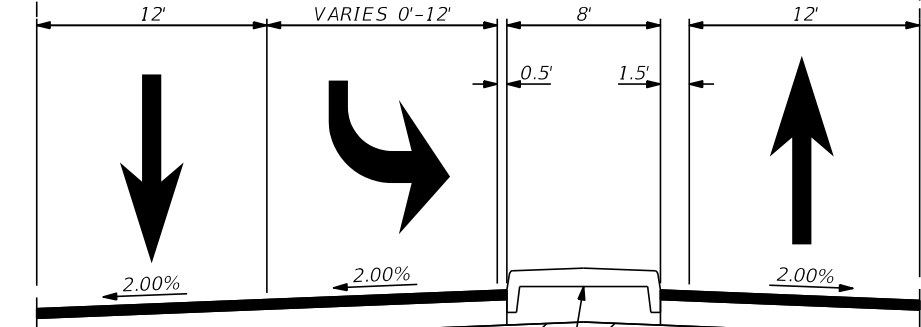

TYPE IV TRAFFIC SEPARATOR
OPTION 1, PER FDOT INDEX 520-020

STA. 118+51.89 TO STA. 121+81.89
 STA. 145+63.49 TO STA. 148+93.54
 STA. 171+60.28 TO STA. 174+90.28

NOTE:
1) ALL SIDEWALK CONSTRUCTED AGAINST THE BACK OF CURB SHALL BE 6' WIDE.

ASPHALT PAVEMENT DESIGN
 TYPE FC-9.5 FRICTION COURSE (TLC, PG 76-22) (1.25")
 TYPE SP-12.5 STRUCTURAL COURSE (TLC, PG 76-22) (1.75")
 CEMENTED COQUINA LBR 100 (10")
 TYPE 'B' STABILIZATION (12")

SHOULDER DESIGN
 TYPE FC-9.5 FRICTION COURSE (TLC, PG 76-22) (1.25")
 CEMENTED COQUINA (LBR 100) (6")
 TYPE 'B' STABILIZATION (12")

POSTED SPEED = 45 MPH
 DESIGN SPEED = 45 MPH

58TH AVENUE
 STA. 111+10.24 TO STA. 175+80.00

ISSUED FOR CONSTRUCTION

REVISIONS							PULTE HOME CORPORATION WATERWAY VILLAGE 58TH AVENUE IMPROVEMENTS	TYPICAL SECTION	SHEET NO.
DATE	BY	DESCRIPTION	DATE	BY	DESCRIPTION				20